

HELIOS DT SUPPRESSOR MANUAL (C)

Before using this product, please take a moment to read and understand this manual. If you have any questions, please feel free to call us at any time!



PRODUCT FEATURES

- Variable Function, CGS silencers are the only silencers in the world capable of being a standard function type silencer or a flow bypass type silencer simply by changing the front cap.
- DMLS (3D Printed) additive manufactured construction provides a stronger and more durable product.
- Modularity on the front end makes the Helios DT very versatile.
- Shallow taper joints are used at the threaded junction to maintain concentricity and provide superior retention.
- Additional parts available for separate purchase depending on user needs.
- Proprietary coating prevents copper/carbon/lead/etc build up within the silencer, but the silencer can still be serviced if and when necessary.

PRODUCT SPECIFICATIONS

- Caliber – 5.56mm
- Length – 6.4” in Default Direct Thread Config
- Diameter – 1.75”
- Weight – 10.6oz in Default Direct Thread Config.
- **10” minimum barrel length (for 5.56 and similar such as 5.45x39)**

MATERIAL SPECIFICATIONS

- Helios DT Core – Grade 5 Titanium
- Default Accessories – Grade 5 Titanium
- Finishes – S-Line (Boron Nitride), black DLC external



HELIOS DT (COM) SUPPRESSOR PARTS DIAGRAM

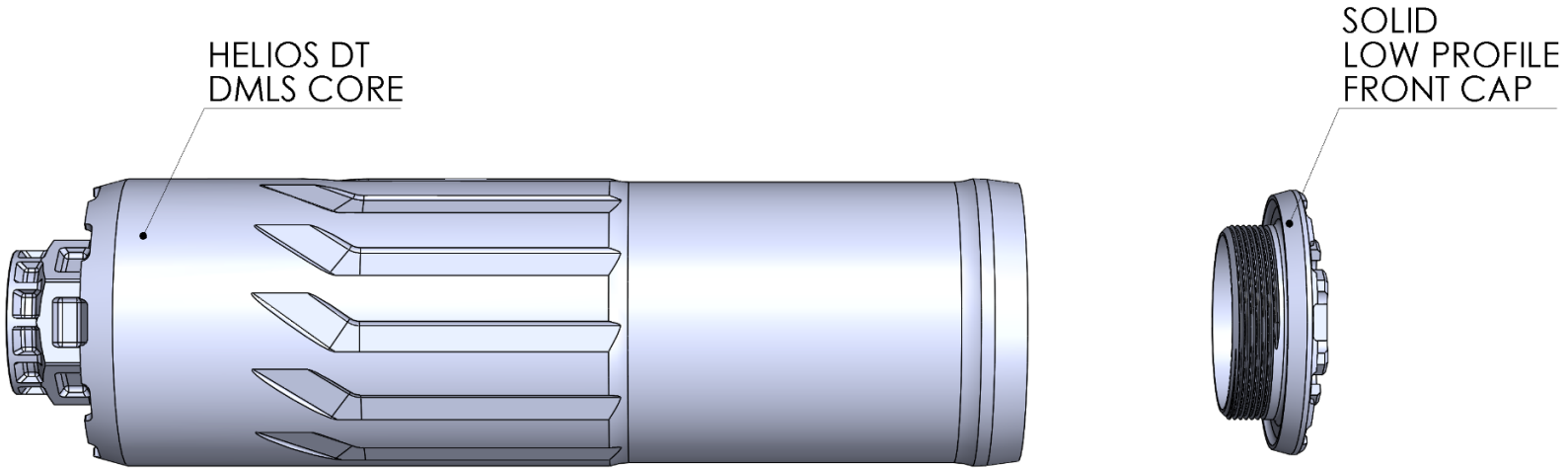

GENERAL OVERVIEW

The Helios DT is based on the original revolutionary design of the CGS Hyperion. The Helios DT is a scaled down version of the Hyperion which has been more optimized for the signature suppression of 5.56 and similar cartridges for use with shorter host firearms and for those which desire lighter weight on their longer barrels.

All CGS rifle silencers at the time of this writing are classified as precision rifle silencers due to their symmetrical design. CGS rifle silencers have very minimal POI shift, if even present, and is often at the 6 o'clock area. Repeatability is excellent due to symmetrical design and concentricity throughout the suppressor.

The CGS Helios DT is limited to barrels of 10" or longer with 5.56 and similar such as 5.45. Currently everything else just has to properly stabilize the projectile. **The Helios QD Ti has a temperature limit of ~850 deg F**, and once reaching this temperature band it should be allowed to cool down. This is because, regardless of who makes a titanium silencer, titanium has inherent material properties which make it more reactive and more rapidly susceptible to particle erosion past this temperature limit. ~850 deg F is around three full auto magazines out of a 10.5" 5.56 host firearm. Most people will never come close to reaching this temperature which is why the Helios QD Ti is beyond suitable for most people. Stuff such as carbine classes and normal shooting is never going to be an issue with this silencer.

The additive manufacturing process we use makes our rifle silencers far stronger than other comparative rifle silencers for a few reasons. Our manufacturing process creates parts with even higher strength and hardness than billet or forgings or castings or MIM, and does so with increased material density. There are no welds so there are no welds to fail and no welds to warp which cause concentricity problems along the length of the silencer. This eliminates welding issues such as welds breaking and their byproducts such as warping, entirely. The monolithic core structure and lack of welds make CGS rifle silencers very strong and eliminates failures, concentricity problems, and QC issues from welds. Even if the weld looks perfectly silver on the exterior you can easily have something that looks fine on the outside, but the weld won't penetrate properly for a number of reasons such as electrical problems within the machine itself, operator error, contamination, etc, so the weld will be very weak and it won't be caught until the weld failure occurs in the end users hands as their using it. That applies to all materials, not just titanium.

The Hyperion VCD (Variable Core Diameter) design itself makes the silencer stronger than any other comparative silencer by better controlling heat and pressure to prevent hot spots from forming. The first chamber is immediately vented and gas is allowed to flow around the first core and is then reintroduced to the main flow further downstream. This also helps reduce thermal signature as well as IR glow under nightvision. Simplicity in design eliminates unnecessary complexity within the silencer. CGS titanium silencers also have a proprietary heat treatment applied which further increases strength and hardness of the silencer core. All CGS rifle silencers are internally coated with hexagonal boron nitride (HBN, S-Line) which decreases friction, increases surface hardness, and prevents fouling from sticking in the first place which eliminates the need to clean because fouling can't easily stick to internal geometry, though they still could be cleaned if ever required. It is a myth that rifle silencers "self-clean" regardless of who makes the silencer (NOTE A). The internal coating also limits/eliminates titanium white sparking depending on cartridge and barrel length. Titanium white sparking is a separate thing from flash and can't be controlled with a flash hider or flash hider front cap. The HBN coating is applied using DCD (Dynamic Compound Deposition) which ensures every internal surface of the silencer is coated properly. The exterior is coated with black DLC applied using PVD (Physical Vapor Deposition).

They're also the only dual function silencers available that can be converted simply by changing out the front cap with a 7/8" wrench. This allows you to have a traditional type silencer and a flow bypass type silencer all in one simple package. With future front cap releases it'll also be adjustable across the entire spectrum of sound, flash, and gas reduction just by swapping out the front cap. These future caps will help alleviate the peripheral flash that plagues the single function flow bypass silencers currently available. No longer do you have to live with just one permanent setting on a silencer. Both front caps and rear caps are retained with shallow taper joints which helps with concentricity and cap retention as it has more grip than a square shoulder. Thanks to the additive manufacturing process this also makes it future proof so regardless of when new front or rear caps are manufactured, they'll always be concentric to the silencer bore.

CGS rifle silencers are also some of the very few that don't sacrifice subsonic performance to achieve supersonic performance, it excels at both without compromise. Usually rifle silencers will either be good at supersonic and mediocre at subsonic, or good at subsonic and mediocre at supersonic. See PewScience.com for details. PEW Science is the definitive source for silencer sound data. It is the only accurate, truthful, unbiased, and independent source of data and analysis available anywhere in the world for silencer sound. Data from other sources not part of the PEW Science pedigree, especially single-point meter data, may not be a reliable indicator of true sound suppression performance of small arms.

Since 99% of strikes occur on the front cap, since we don't use any welds in our silencers which eliminates concentricity problems, and since our DMLS additive manufacturing process creates a superior product in every meaningful way there's nothing that's going to need repairing other than on extremely rare occasion the front cap, and even then, front cap repairs are exceedingly rare. In over four years at the date of this writing, no DMLS rifle silencer cores have been returned for repair from military, government, or commercial customers or consultants because the root of the primary problems from which strikes stem are eliminated. Core strike potential is a complete non-issue.

The exterior rear of the core features a 7/8" hex for a crescent wrench or open end wrench and the front caps have a 7/8" hex for crescent or open end wrenches or sockets and are substantial enough to use with most wrenches.

OVERALL LENGTH (including rear hex feature and Low Profile Front Cap front hex feature) – 6.4"

ADDED LENGTH – (assuming .625" barrel threads) 5.77"

CORE ASSEMBLY WEIGHT – 10.6oz

DIAMETER - 1.75"

REAR HEX – EXTERIOR 7/8"

FRONT CAP HEX - EXTERIOR 7/8"

NOTE A / CLEANING - All rifle silencers will build up fouling over time, regardless of what manufacturers choose to tell consumers. It is an internet myth that rifle silencers don't need to be cleaned, there is an abundance of actual physical evidence from many companies in the silencer industry that rifle silencers do accumulate fouling (copper/lead/carbon/etc) and that they do need to be cleaned as that fouling can lead to significant weight gain, significant sound increase, flash performance reduction, and in some cases accuracy issues. It is best practice to weigh the silencer and record the base weight prior to use. Then every 1-3000rds weigh it again and see how much build up it has inside. After an ounce or so builds up then clean it according to the manufacturer's instructions. The S-Line internal coating used in all CGS rifle silencers prevents most build up from occurring in the first place, which is something that nearly all other silencers do not have. Cleaning of the Hekate can be accomplished when needed by dunking the core in solvent for 24-48hrs and then draining it. You can then shoot a mag through it (using the Vented front cap or no front cap installed) to remove whatever fouling is loose. Repeat as needed. But chances are you will not get any meaningful build up over the course of tens of thousands of rounds thanks to the internal S-Line/Hexagonal Boron Nitride coating.

NOTE B / FIRST USE – Upon first use of the Helios DT you may notice white sparking out the bore. This is due to the manufacturing process using titanium powder material finely processed into a consistency similar to that of talcum powder. To completely remove this residual fine powder from the manufacturing process, simply shoot the silencer and it'll go away over the course of 20 or so rounds, then the internal coating of Hexagonal Boron Nitride will do its job to limit/eliminate white sparking out the bore of the silencer. In short, just shoot your silencer and this white sparking will nearly cease to occur.

ASSEMBLY / DISASSEMBLY

Prior to use, ensure all taper shoulders are clean, threads are greased, and that components are properly shouldered against their corresponding surfaces and tightly secured to correct torque values. Front Caps should be tightened to the Helios DT at 20-25ft/lb.

1. Thread the Front Cap into the front of the Helios DT until hand tight (**Images 1-2**)
2. Using a torque wrench on the 7/8" wrench flats on the Front Cap, and while holding the core either by hand or with another hex wrench, tighten together until 20-25ft/lbs is achieved. (**Image 3**)

NOTE:

If the suppressor parts appear to be misaligned when assembled, stop the installation process and contact **CGS**. Use of the suppressor if not properly assembled can cause damage to the suppressor and firearm and could cause injury to the shooter.

If you experience loosening of threaded joints during shooting it is recommended to degrease the threads and use a quality thread locker such as Vibra-Tite 123 and reasonably increase torque value.

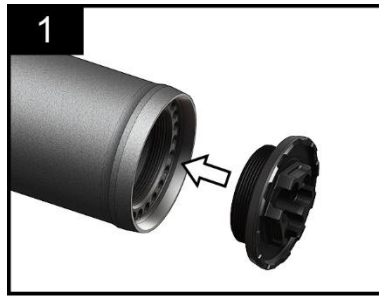

To disassemble, simply reverse Steps 1 through 3.

INSTALLATION

1. Remove the magazine from the firearm, then visually and manually check and clear the action and chamber of the firearm. Make sure the host firearm is unloaded at all times.
2. Check the barrel threads to ensure they are clean and free of debris. **(Image 7)**
3. Thread the assembled Helios DT clockwise onto the barrel threads, being careful not to cross thread, until hand tight and secure against the shoulder of the barrel. **(Image 8-9)**
4. For normal use, very hand tight will do. For extended use, torque the Helios DT using the 7/8" wrench flats to the barrel threads to 25-30ft/lbs while using an armorers tool such as the Geissele Reaction Rod (if needed) to prevent tweaking or damage to the host firearm gas system or barrel assembly.
5. Visually inspect that the suppressor is mounted straight to the centerline of the bore. Ensure that it is not tilted or canted in any way, and that it is fully shouldered and secure on the barrel. **(Images 10-11)**

NOTE:

If the suppressor appears to be misaligned, stop the installation process and contact CGS.

Use of the suppressor if not properly mounted will cause damage to the suppressor and firearm and could cause injury to the shooter.

To uninstall, simply reverse Steps 3 and 4.

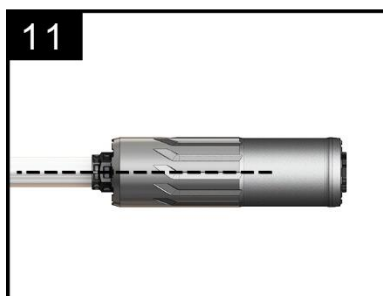
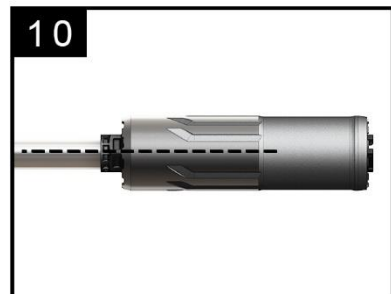
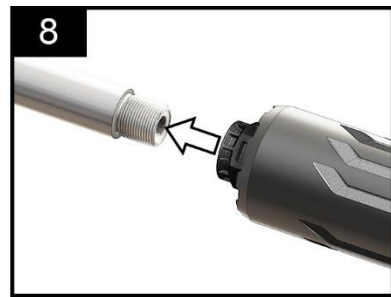
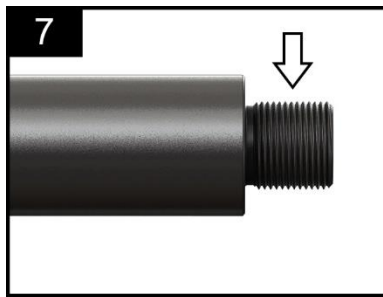

MAINTENANCE

1. It is recommended that the suppressor be weighed prior to use and recorded, and at intervals of 1000-3000 rounds depending on the ammunition being used record the weight and round count. Once the Helios DT is an extra ounce or two over the base weight, it is a good time to clean the silencer. Only clean if actually necessary.
2. If cleaning becomes necessary, disassemble, and dunk the Helios DT Core in a titanium safe solvent for 24-48 hours.
3. After the soak time has elapsed, assemble the Helios DT and ensure all taper shoulders are clean, threads are greased, and that components are properly shouldered against their corresponding surfaces and tightly secured to correct torque values.
4. Ensure the suppressor has drained completely and fire ~10rds through it with the front cap removed. This will blow out any excess solvent. Installed desired front cap after this process is complete.
5. Do not use a bore patch or jag to clean the suppressor.
6. After cleaning a light coating of grease should be applied the threads, and all taper shoulders should be cleaned.

WARNINGS AND DISCLAIMERS

- Always practice the basic rules of firearms safety when using the suppressor.
- Silencers may loosen during firing. It is important that you frequently verify that your suppressor is securely tightened during use. It is recommended that you check for tightness every 30 rounds and use gloves or another barrier to ensure you are not burned.
- **CGS** is not responsible or liable for damages or injuries resulting from the improper use of this product; it is the user's responsibility to read and completely understand the instructions in this manual before using this product.

AMMUNITION RECOMMENDATIONS

- The Helios DT was designed for semi auto firing of factory 5.56mm and similar ammunition only. Contact **CGS** regarding other types of ammunition.
- We recommend the use of high quality factory loaded ammunition with this product for best sound performance, accuracy, and reliability.
- Suppressors are designed to attenuate the muzzle blast of a firearm, but they do not alter or suppress the sonic crack caused by supersonic projectiles as they break the sound barrier. Subsonic ammunition may be used.

AMMUNITION RECOMMENDATIONS

- The minimum barrel length allowed is 10.0" for 5.56x45mm NATO. For any other questions on what is allowed, contact CGS with specific information about your intended use (host, barrel length, cartridge, etc).

WARRANTY

Subject to restrictions, CGS warrants this suppressor to be free from any manufacturing defects for life. In the unlikely event that you received a defective product, **CGS** will repair or replace the suppressor; it is at the discretion of CGS to determine if a particular defect or condition is covered by this warranty.

If a repair is necessary, please contact CGS at Sales@csgsgroup.com to make arrangements for the proper and legal return of the product.

Please do not ship anything to CGS without first contacting CGS.

CGS Group, LLC

Customer Service

Sales@CGSGroup.com

© 2019 CGS Group LLC. All rights reserved.