

HELIOS QD TI SUPPRESSOR MANUAL (C)

Before using this product, please take a moment to read and understand this manual. If you have any questions, please feel free to call us at any time!

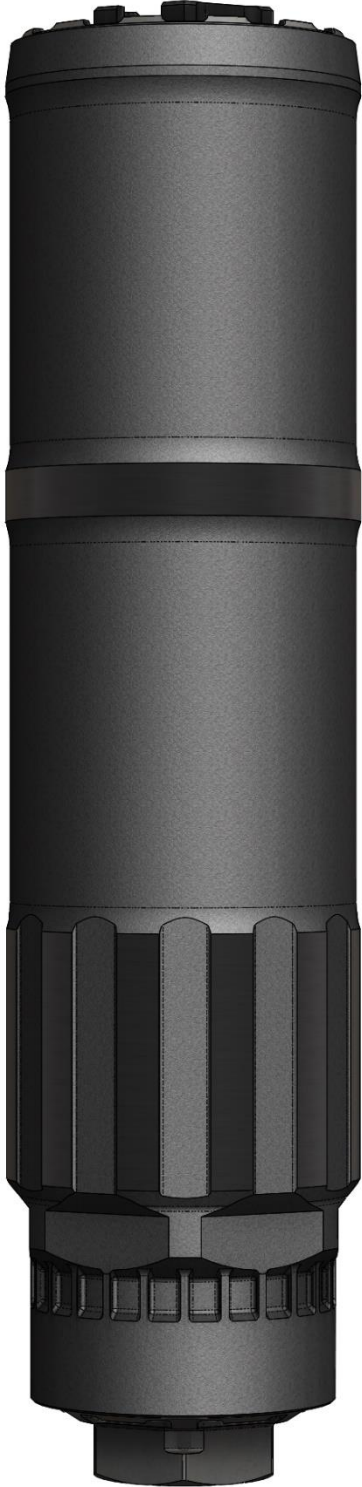

PRODUCT FEATURES

- Variable Function, CGS silencers are the only silencers in the world capable of being a standard function type silencer or a flow bypass type silencer simply by swapping the front cap with a 7/8" wrench.
- DMLS (3D Printed) additive manufactured construction provides a stronger and more durable product.
- Modularity at both ends makes it the most versatile and capable silencer available.
- Shallow taper joints are used at each threaded junction to maintain concentricity and provide superior retention.
- Comes with many feature-rich accessories with additional parts available for separate purchase depending on user needs.
- Proprietary coating prevents copper/carbon/lead/etc build up within the silencer, but the silencer can still be serviced if and when necessary.

PRODUCT SPECIFICATIONS

- Caliber – 5.56mm, but up to 7.62mm Capable.
- Length – 7.2" in Direct Thread Config.
- Diameter – 1.5" at Rear, 1.75" at Front.
- Weight – 11.6oz in 1/2X28 Direct Thread Config, 11oz with QD Adapter Ring.
- **10" minimum barrel length (5.56 and similar such as 5.45x39).**

MATERIAL SPECIFICATIONS

- Helios QD Ti Core – Grade 5 Titanium
- Kit Accessories – Grade 5 Titanium
- Finishes – S-Line (HBN) internal, black DLC external



HELIOS QD TI (COM) SUPPRESSOR PARTS DIAGRAM

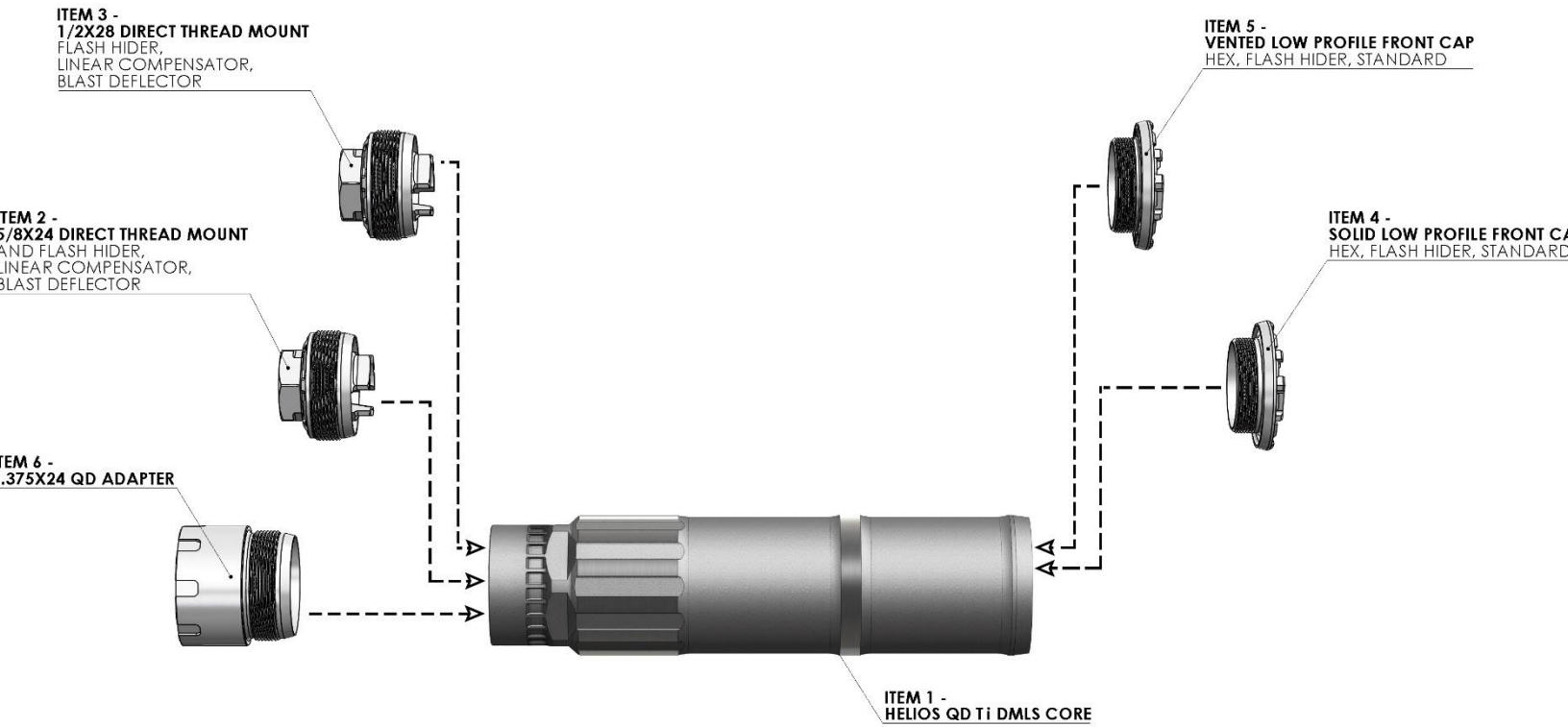

GENERAL OVERVIEW

The Helios QD Ti is based on the Helios QD, which is a shorter variant of CGS Hyperion Technology utilizing 1.375x24 pattern QD mount compatibility. The Helios QD, which this titanium variant is based on, was made for left handed shooters to reduce/eliminate toxic gas in the face depending on the host firearm and was originally made for a 10.4" select fire 5.56 carbine and similar hosts such as the MK18 as well as for the M249, MK46, and variants. In some cases, the Helios QD Ti is quieter than some other companies' fullsize rifle silencers even though the Helios QD Ti is only 6.58" added length in its default direct thread state. As most people will never need a heavy duty silencer for extreme hard use with short barrel rifles, machine guns, and belt feds, the Helios QD Ti will fit the bill for the vast majority of peoples realistic, practical uses.

The Helios QD Ti is built as a lightweight, and the first of its type dual function, 5.56mm silencer that just happens to have a bore large enough to pass a 7.62mm projectile. It's a lightweight 5.56 silencer first and foremost, but with the balancing act to get it where we wanted for sound at the ear and muzzle, we settled on a bore diameter that just happens to fit 7.62mm projectiles. Using the larger bore on a 5.56mm silencer helps achieve better sound at the ear on some 5.56mm and similar semi auto hosts. The .355-.375" bore diameter tapering larger going forward also helps with unstable 5.56mm and similar, basically eliminating the potential for strikes. The rear socket is modular, so you can use it as a direct thread silencer or you can use it with any 1.375x24 pattern QD mount. All CGS rifle silencers at the time of this writing are classified as precision rifle silencers due to their symmetrical design. CGS rifle silencers have very minimal POI shift, if even present, and is often at the 6 o'clock area. Repeatability is excellent due to symmetrical design and concentricity throughout the suppressor.

The CGS Helios QD Ti is limited to barrels of 10" or longer with 5.56 and similar such as 5.45. Currently everything else just has to properly stabilize the projectile, such as using a 1:5 twist rate on 5.5" 300 Blackout subsonic. **The Helios QD Ti has a temperature limit of ~850 deg F**, and once reaching this temperature band it should be allowed to cool down. This is because, regardless of who makes a titanium silencer, titanium has inherent material properties which make it more reactive and more rapidly susceptible to particle erosion past this temperature limit. ~850 deg F is around three full auto magazines out of a 10.5" 5.56 host firearm. Most people will never come close to reaching this temperature which is why the Helios QD Ti is beyond suitable for most people. Stuff such as carbine classes and normal shooting is never going to be an issue with this silencer. And in the future other accessories will be available which will further enhance the capabilities of the Helios QD Ti.

The CGS Helios QD Ti comes with:

- 1) Helios QD Ti Core
- 2) 5/8 x 24 TPI Direct Thread Mount
- 3) 1/2 x 28 TPI Direct Thread Mount
- 4) Solid Low Profile Front Cap, Hex, Flash Hider, Standard
- 5) Vented Low Profile Front Cap, Hex, Flash Hider, Standard
- 6) QD Adapter Mount for 1.375 x 24 TPI pattern QDs from various companies
- 7) Hook Wrench for QD adapter (various other companies hook wrench products may be used if they fit)
- 8) SKB Hard Case for all components

The additive manufacturing process we use makes our rifle silencers far stronger than other comparative rifle silencers for a few reasons. Our manufacturing process creates parts with even higher strength and hardness than billet or forgings or castings or MIM, and does so with increased material density. There are no welds so there are no welds to fail and no welds to warp which cause concentricity problems along the length of the silencer. This eliminates welding issues such as welds breaking and their byproducts such as warping, entirely. The monolithic core structure and lack of welds make CGS rifle silencers very strong and eliminates failures, concentricity problems, and QC issues from welds. Even if the weld looks perfectly silver on the exterior you can easily have something that looks fine on the outside, but the weld won't penetrate properly for a number of reasons such as electrical problems within the machine itself, operator error, contamination, etc, so the weld will be very weak and it won't be caught until the weld failure occurs in the end users hands as their using it. That applies to all materials, not just titanium.

The Hyperion VCD (Variable Core Diameter) design itself makes the silencer stronger than any other comparative silencer by better controlling heat and pressure to prevent hot spots from forming. The first chamber is immediately vented and gas is allowed to flow around the first core and is then reintroduced to the main flow further downstream. This also helps reduce thermal signature as well as IR glow under nightvision. Simplicity in design eliminates unnecessary complexity within the silencer. CGS titanium silencers also have a proprietary heat treatment applied which further increases strength and hardness of the silencer core. All CGS rifle silencers are internally coated with hexagonal boron nitride (HBN, S-Line) which decreases friction, increases surface hardness, and prevents fouling from sticking in the first place which eliminates the need to clean because fouling can't easily stick to internal geometry, though they still could be cleaned if ever required. It is a myth that rifle silencers "self-clean" regardless of who makes the silencer (NOTE A). The internal coating also limits/eliminates titanium white sparking depending on cartridge and barrel length. Titanium white sparking is a separate

thing from flash and can't be controlled with a flash hider or flash hider front cap. The HBN coating is applied using DCD (Dynamic Compound Deposition) which ensures every internal surface of the silencer is coated properly. The exterior is coated with black DLC applied using PVD (Physical Vapor Deposition).

They're also the only dual function silencers available that can be converted simply by changing out the front cap with a 7/8" wrench. This allows you to have a traditional type silencer and a flow bypass type silencer all in one simple package. With future front cap releases it'll also be adjustable across the entire spectrum of sound, flash, and gas reduction just by swapping out the front cap. These future caps will help alleviate the peripheral flash that plagues the single function flow bypass silencers currently available. No longer do you have to live with just one permanent setting on a silencer. Both front caps and rear caps are retained with shallow taper joints which helps with concentricity and cap retention as it has more grip than a square shoulder. Thanks to the additive manufacturing process this also makes it future proof so regardless of when new front or rear caps are manufactured they'll always be concentric to the silencer bore.

CGS rifle silencers are also some of the very few that don't sacrifice subsonic performance to achieve supersonic performance, it excels at both without compromise. Usually rifle silencers will either be good at supersonic and mediocre at subsonic, or good at subsonic and mediocre at supersonic.

Since 99% of strikes occur on the front cap, since we don't use any welds in our silencers which eliminates concentricity problems, and since our DMLS additive manufacturing process creates a superior product in every meaningful way there's nothing that's going to need repairing other than on an extremely rare occasion the front cap, and even then, front cap repairs are exceedingly rare. In over four years at the date of this writing, no DMLS rifle silencer cores have been returned for repair from military, government, or commercial customers or consultants because the root of the primary problems from which strikes stem are eliminated. Core strike potential is a complete non-issue.

The exterior of the core features a 1.5" hex for a crescent wrench and the rear caps and front caps have a 7/8" hex for crescent or open end wrenches or sockets and are substantial enough to use with most wrenches. The direct thread mounts are made of Grade 5 titanium. These have a wide 7/8" sunken hex on the rear so most common size sockets will fit. It also has a 3/4" hex on the opposite side so in the very unlikely event the direct thread mount somehow comes loose from the silencer core, especially when mounted under a rail, the direct thread mount can be easily removed from the barrel separately using a socket or a wrench. In the future we will offer some rear caps with the SIG 25 deg taper for better compatibility with their products and for those that like to use that feature on their direct thread configs.

A separate QD Adapter for 1.375 x 24 TPI pattern QD mounts can be purchased which will allow the Helios QD to adapt to any company's QD mount that is compatible with that system. The CGS QD Adapter still interfaces with the shallow taper on the Helios QD Ti core. Since all the 1.375x24 pattern QDs from other companies sit on a normal 90 degree shoulder there are no worries about anything coming loose. Obviously when you install a 1.375x24 pattern QD you lose the benefit of the better concentricity that the QD Adapter taper joint provides for, but no big deal there as that already applies to every silencer available that has that compatibility. The hook wrench will be included with the QD Adapter which can interface with the notches on the exterior of the QD adapter for those people that don't already have a hook wrench that can do that job. The QD adapter is long by default to be compatible with everything currently made by default. When installing a QD mount to the CGS QD Adapter, install the QD mount to the CGS QD Adapter first, and then installed the CGS QD Adapter to the Helios QD core.

OVERALL LENGTH (including Direct Thread Mount rear hex feature and Low Profile Front Cap front hex feature) – 7.2"
ADDED LENGTH – (assuming .625" barrel threads) 6.58"
CORE ASSEMBLY WEIGHT (default 1/2x28 direct thread) - 11.6oz
DIAMETER - 1.75" (on main body) 1.5" (on rear body)
REAR CAP HEX – EXTERIOR 7/8", INTERIOR 3/4"
FRONT CAP HEX - EXTERIOR 7/8"

NOTE A / CLEANING - All rifle silencers will build up fouling over time, regardless of what manufacturers choose to tell consumers. It is an internet myth that rifle silencers don't need to be cleaned, there is an abundance of actual physical evidence from many companies in the silencer industry that rifle silencers do accumulate fouling (copper/lead/carbon/etc) and that they do need to be cleaned as that fouling can lead to significant weight gain, significant sound increase, flash performance reduction, and in some cases accuracy reduction. It is best practice to weigh the silencer and record the base weight prior to use. Then every 1-3000rds weigh it again and see how much build up it has inside. After an ounce or so builds up then clean it according to the manufacturer's instructions. The S-Line internal coating used in all CGS rifle silencers prevents most build up from occurring in the first place, which is something that nearly all other silencers do not have. Cleaning of the Helios QD can be accomplished when needed by dunking the core in solvent for 24-48hrs and then draining it. You can then shoot a mag through it (using the Vented front cap or no front cap installed) to remove whatever fouling is loose. Repeat as needed. But chances are you will not get any meaningful build up over the course of tens of thousands of rounds thanks to the internal S-Line coating.

ASSEMBLY

Prior to use, ensure all taper shoulders are clean, threads are greased, and that components are properly shouldered against their corresponding surfaces and tightly secured to correct torque values. Caps should be tightened to the Helios QD Ti Core at 25-30ft/lb.

1. Remove the magazine from the firearm, then visually and manually check and clear the action and chamber of the firearm. Make sure the host firearm is unloaded at all times.
2. Thread the Direct Thread Rear Cap of choice into the rear of the Helios Core until hand tight. **(Image 1-2)**
3. Using a torque wrench on either the 1.5" wrench flats of the Helios Core or the 7/8" socket on the Rear Cap, and while holding the other part with another wrench, tighten together until 25-30ft/lbs is achieved. **(Image 3)**
4. Thread the Front Cap into the front of the Helios QD Ti Core until hand tight **(Images 4-5)**
5. Using a torque wrench on either the 1.5" wrench flats of the Helios Core or the 7/8" wrench flats on the Front Cap, and while holding the other part with another wrench, tighten together until 20-25ft/lbs is achieved. **(Images 6)**

NOTE:

If the suppressor parts appear to be misaligned when assembled, stop the installation process and contact **CGS**. Use of the suppressor if not properly assembled can cause damage to the suppressor and firearm and could cause injury to the shooter.

If you experience loosening of threaded joints during shooting it is recommended to degrease the threads and use a quality thread locker such as Vibra-Tite 123 and reasonably increase torque value.

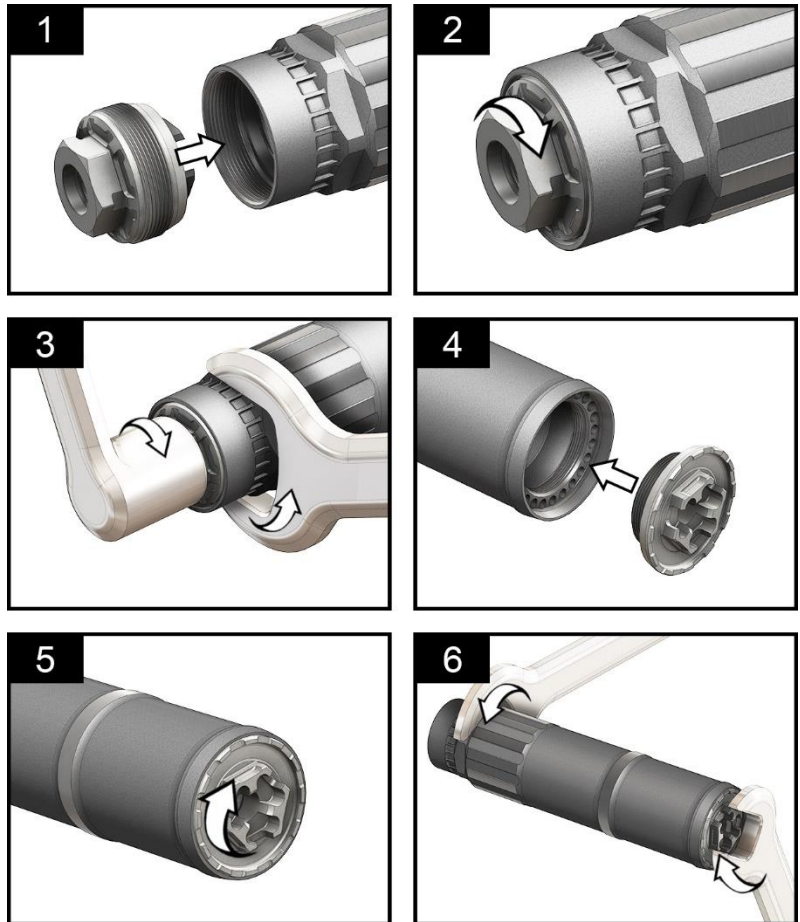

INSTALLATION

1. Remove the magazine from the firearm, then visually and manually check and clear the action and chamber of the firearm. Make sure the host firearm is unloaded at all times.
2. Check the barrel threads to ensure they are clean and free of debris. **(Image 7)**
3. Thread the assembled Helios QD Ti clockwise onto the barrel threads, being careful not to cross thread, until hand tight and secure against the shoulder of the barrel. Depending on the length of the host firearm barrel threads, the Helios QD Ti will shoulder on either the shoulder behind the threads or the shoulder on the muzzle. **(Image 8-9)**
4. For normal use, very hand tight will do. For extended use, torque the Helios QD Ti using the 3/4" wrench flats on the Rear Cap to the barrel threads to 25-30ft/lbs while using an armorer's tool such as the Geissele Reaction Rod to prevent tweaking or damage to the host firearm gas system or barrel assembly, then install the Helios QD Ti Core to the Rear Cap.
5. Visually inspect that the suppressor is mounted straight to the centerline of the bore. Ensure that it is not tilted or canted in any way, and that it is fully shouldered and secure on the barrel. **(Images 10-11)**

NOTE:

If the suppressor appears to be misaligned, stop the installation process and contact **CGS**.

Use of the suppressor if not properly mounted will cause damage to the suppressor and firearm and could cause injury to the shooter.

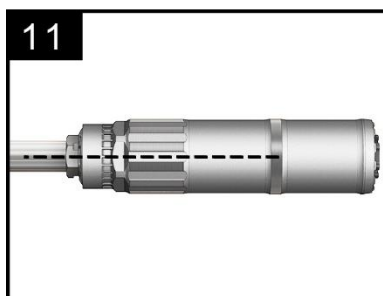
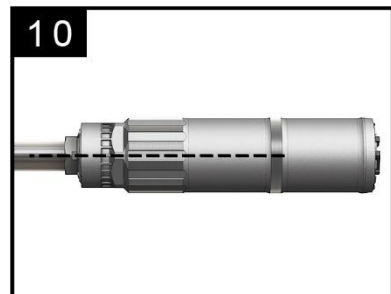
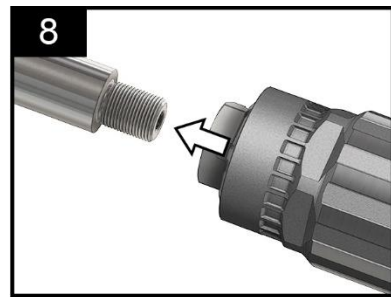
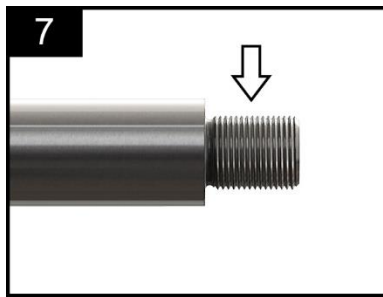

REMOVAL

CAUTION! Do not attempt to remove the suppressor if it is hot.

1. Remove the magazine from the firearm, then visually and manually check and clear the action and chamber of the firearm. Make sure the host firearm is unloaded at all times.
2. Rotate the suppressor counterclockwise until it has been removed from the muzzle of the firearm. **(Images 12-13)**

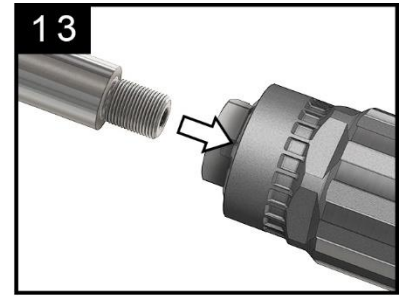
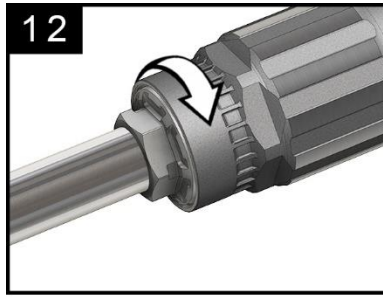

DISASSEMBLY

1. With the suppressor removed from the firearm and using a 7/8 wrench or socket, unscrew the Front End Cap and remove it from the suppressor while holding the Helios QD Ti Core with a 1.5" wrench. (Images 14-15)
2. With the suppressor removed from the firearm and using a 7/8 wrench or socket, unscrew the Rear End Cap and remove it from the suppressor while holding the Helios QD Ti Core with a 1.5" wrench. (Images 16-17)

The suppressor is now completely disassembled and ready for cleaning.

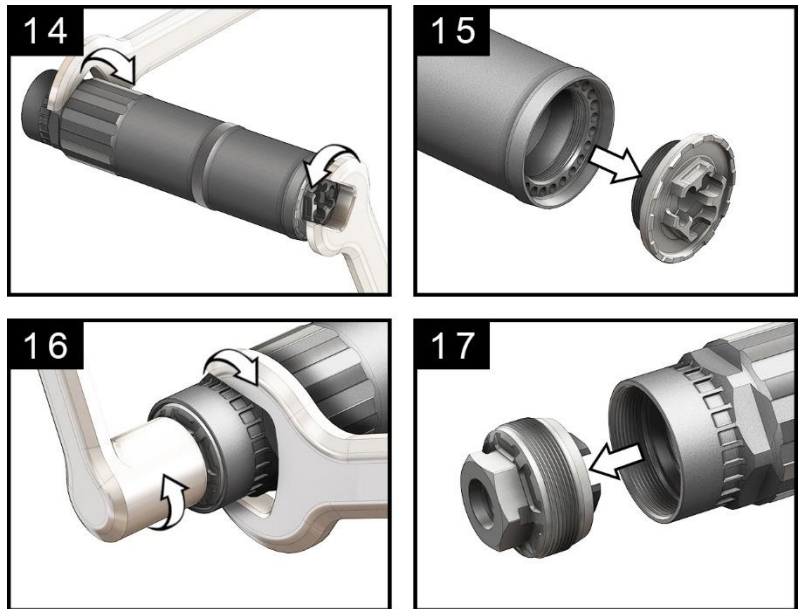

CLEANING NOTES:

- 1) Only clean if actually necessary, when more than 1-2 ounces of weight has been added to the base recorded weight prior to use.
- 2) If cleaning becomes necessary, dunk the Helios QD Ti Core in a titanium safe solvent for 24-48 hours.
- 3) After the soak time has elapsed, assemble the Helios QD Ti and ensure all taper shoulders are clean, threads are greased, and that components are properly shouldered against their corresponding surfaces and tightly secured to correct torque values.
- 4) Ensure the suppressor has drained completely and fire ~10rds through it with the front cap removed or with the Full Vent Front Cap installed. This will blow out any excess solvent. Installed desired front cap after this process is complete.

ASSEMBLY OF THE QD ADAPTER

Prior to use, ensure all taper shoulders are clean, threads are greased, and that components are properly shouldered against their corresponding surfaces and tightly secured to correct torque values. Caps should be tightened to the Helios Core at 25-30ft/lb.

1. Remove the magazine from the firearm, then visually and manually check and clear the action and chamber of the firearm. Make sure the host firearm is unloaded at all times.
2. Thread the compatible 1.375x24 pattern QD of choice into the rear of the CGS QD Adapter until hand tight. **(Image 18-19)**
3. Using a torque wrench on the hex tool feature of the chosen 1.375x24 pattern QD, if it allows, and using the Hook Wrench in the provided slots in the CGS QD Adapter, tighten together until 25ft/lb is achieved, or the torque value as stated by the manufacturer of the compatible QD device. **(Image 20)**
4. Thread the CGS QD Adapter assembly into the rear of the CGS QD Adapter until hand tight. **(Image 21-22)**
5. Using a torque wrench on the 1.5" wrench flats of the Helios Core and while using the Hook Wrench in the provided slots in the CGS QD Adapter, tighten together until ~30ft/lbs is achieved. You want it to be very tight as with all threaded joints. **(Image 23)**

NOTE:

If the suppressor parts appear to be misaligned when assembled, stop the installation process and contact **CGS**. Use of the suppressor if not properly assembled can cause damage to the suppressor and firearm and could cause injury to the shooter.

The depicted generic mount on the left in #18 is not included with the Helios QD Ti, it just represents any 1.375x24 compatible QD mount.

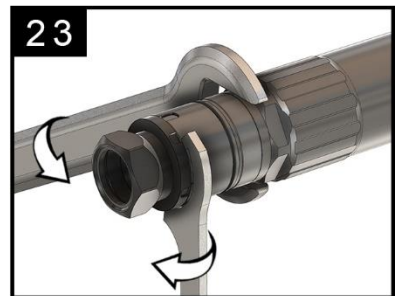
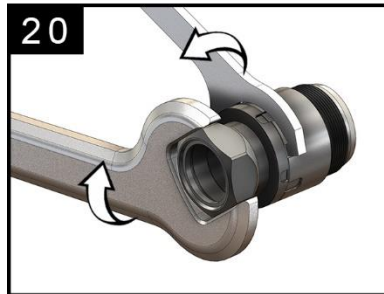

If you experience loosening of threaded joints during shooting it is recommended to degrease the threads and use a quality thread locker such as Vibra-Tite 123.

MAINTENANCE

1. It is recommended that the suppressor be weighed prior to use and recorded, and at intervals of 1000-3000 rounds depending on the ammunition being used record the weight and round count. Once the Helios QD Ti is an extra ounce or two over the base weight, it is a good time to clean the silencer. Only clean if actually necessary.
2. If cleaning becomes necessary, disassemble, and dunk the Helios Ti Core in a titanium safe solvent for 24-48 hours.
3. After the soak time has elapsed, assemble the Helios QD Ti and ensure all taper shoulders are clean, threads are greased, and that components are properly shouldered against their corresponding surfaces and tightly secured to correct torque values.
4. Ensure the suppressor has drained completely and fire ~10rds through it with the front cap removed or with the Full Vent Front Cap installed. This will blow out any excess solvent. Installed desired front cap after this process is complete.
5. Do not use a bore patch or jag to clean the suppressor.
6. After cleaning a light coating of grease should be applied the threads, and all taper shoulders should be cleaned.

WARNINGS AND DISCLAIMERS

- Always practice the basic rules of firearms safety when using the suppressor.
- Silencers may loosen during firing. It is important that you frequently verify that your suppressor is securely tightened during use. It is recommended that you check for tightness every 30 rounds and use gloves or another barrier to ensure you are not burned.
- If you properly torque the silencer components together and use a wrench to torque the silencer to the barrel to the proper torque value, there's no chance of the silencer coming loose. Always torque the silencer to the barrel using a wrench when possible.
- CGS is not responsible or liable for damages or injuries resulting from the improper use of this product; it is the user's responsibility to read and completely understand the instructions in this manual before using this product.

AMMUNITION RECOMMENDATIONS

- The Helios QD Ti was designed for semi auto and full auto firing of factory 5.56mm, 7.62mm, 6mm, 6.5mm, 6.8mm, 7.62x39, 300 AAC Blackout and similar ammunition. Contact **CGS** regarding other types of ammunition.
- We recommend the use of high quality factory loaded ammunition with this product for best sound performance, accuracy, and reliability.
- Suppressors are designed to attenuate the muzzle blast of a firearm, but they do not alter or suppress the sonic crack caused by supersonic projectiles as they break the sound barrier. Subsonic ammunition may be used.

BARREL LENGTH RESTRICTIONS

- **The minimum barrel length allowed is 10.0" specifically for 5.56x45mm NATO and similar such as 5.45.** Other cartridges currently have no barrel length restrictions provided the projectile is properly stabilized. For any other questions on what is allowed, contact CGS with specific information about your intended use (host, barrel length, cartridge, etc).

WARRANTY

Subject to restrictions, CGS warrants this suppressor to be free from any manufacturing defects for life. In the unlikely event that you received a defective product, **CGS** will repair or replace the suppressor; it is at the discretion of CGS to determine if a particular defect or condition is covered by this warranty.

If a repair is necessary, please contact CGS at sales@csgsgroup.com for a CGS representative to make arrangements for the proper and legal return of the product. **Please do not ship anything to CGS without first contacting CGS.**

CGS Group, LLC

Customer Service

Sales@csgsgroup.com

© 2019 CGS Group LLC. All rights reserved.