

CGS GROUP LLC PANDORA™ FIRING DEVICE

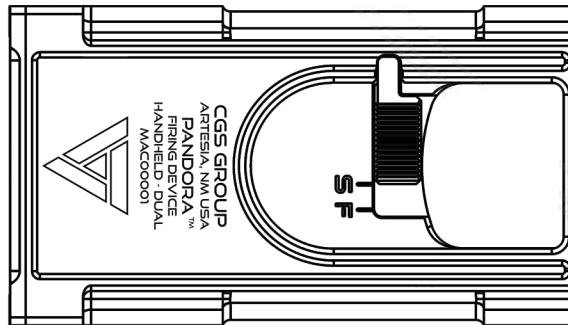

FEATURES

- Designed and manufactured in Artesia, New Mexico USA to the highest standards, the **CGS PANDORA™** contains multiple safety features in a small 4.4 x 2.5 x 0.87" envelope and weighs in at just 8.7 ounces, lighter than the current MK54 Mod 1.
- Hands down the safest, easiest to use, sleekest, most modular, and most user friendly firing device on the market today.
- While incredibly safe, the double action only striker fired method of operation is effortless to use, allowing for one handed operation and allows the operator to focus on his or her surroundings, and requires very little end user training.
- Simply slide the Safety Switch from either side of the device to the fire position and pull the Trigger to the rear to fire the device.
- The only time the **CGS PANDORA™** is ever cocked is when the user is in the process of pulling the Trigger to fire the device. The firing channels are separated and each Striker has its own Sear allowing for true independent Striker movement.
- A first for a mechanical firing device is an instantly available restrike capability. If your explosive charge doesn't detonate on the first try, just release the Trigger and pull again to restrike as many times as necessary.
- After firing, each Striker is immediately and automatically locked to a rearward safe position behind its own Striker Block, away from the primers of the Direct Fire System or adapters to ensure safety at all times. The Strikers won't protrude into the primers unless having been immediately fired, ensuring automatic passive safety engagement even when the external safety switch is in the fire position. In the event a Striker Block is nonfunctional, the sears automatically act as secondary passive safeties.
- The **CGS PANDORA™** is simple to assemble/disassemble, easy to clean, and features a unique modular design. Remove two T10 Torx Screws on the rear of the device and push in the Guide Rod protruding into the Rear Plate and slide the Rear Plate out of the device. The Guide Rod/Spring, Trigger Pack, and Mounting Plate will slide out of the housing allowing the operator to slide in a different Mounting Plate and/or Rear Plate for various methods of attachment and features.
- Mounting plates are available which will attach the **CGS PANDORA™** to a pole arm for breaching windows or similar stand off use, for mounting to a MIL-STD-1913 rail (male or female) using an off the shelf QD throw lever mount allowing for orientation in 90 degree increments, for attaching two **CGS PANDORA™** devices back to back, for screw attachments to wooden or similar objects, or for a plate with Velcro or similar for attaching to a plate carrier. A Rear Plate is available which features a folding, locking non-electric shock tube cutter which adds only .2" to overall length.
- Internal parts are nearly 100% closed off from external environmental elements, ensuring clear function and far less maintenance compared to traditional designs. Simple assembly and disassembly and a fixed headspace allow the end user to service the device in the field if it becomes necessary. This sealed design coupled with fixed headspace ensures the utmost reliability.
- The **CGS PANDORA™** is constructed of a combination of 7075 T6 Aluminum, 17-4PH Stainless Steel, and S7 Tool Steel. All aluminum parts are Type III Hardcoat Anodized. Stainless Steel/Tool Steel parts are heat treated for strength and hardness and Black Oxide coated. Many Cerakote color options are also available.
- The **CGS PANDORA™** fits perfectly in an M16 size magazine pouch, both nylon and Kydex.



EXPORT OF THIS PRODUCT IS STRICTLY PROHIBITED WITHOUT A VALID EXPORT LICENSE ISSUED BY THE US DEPARTMENT OF STATE, OFFICE OF DEFENSE TRADE CONTROLS PRESCRIBED IN THE INTERNATIONAL TRAFFIC IN ARMS REGULATIONS (ITAR) TITLE 22, CFR, PARTS 120-130.